

MicroCool Fogging Solutions



IBEX SERIES 4-11 gpm Installation & Maintenance Manual

MicroCool®

72216 Northshore Street

Thousand Palms, CA 92276, USA

www.microcool.com

fog@microcool.com

Phone: +1-760-322-1111

Fax: +1-760-343-1820

**DISTRIBUTED BY
OG INDUSTRIES, LLC
Phone: 484-461-3030**

www.industrialodorgone.com

Table of Contents

1.	BEFORE STARTING	5
1.1	CRANKCASE OIL PLUG	5
1.2	OIL LEVEL	5
1.3	INLET WATER SUPPLY PRESSURE	5
1.4	OIL CHANGE INTERVAL	5
1.5	HIGH PRESSURE FITTINGS	5
1.6	INLET WATER SUPPLY PLUMBING MATERIAL	5
1.7	FLUSHING THE SYSTEM	5
1.8	TEFLON TAPE	5
2.	WATER QUALITY	6
2.1	TOTAL DISSOLVED SOLIDS COUNT	6
2.2	WATER ANALYSIS	6
2.3	WATER TREATMENT	6
2.4	ULTRAVIOLET WATER PURIFIERS	6
2.5	REVERSE OSMOSIS WATER TREATMENT	6
3.	INSTALLATION OF THE PUMP MODULE	7
3.1	POSITIONING THE PUMP MODULE	7
3.2	WATER SUPPLY AND CONNECTION	7
3.3	DRAINAGE FROM THE PUMP	7
4.	PUMP MODULE POWER SUPPLY	8
4.1	CAUTION!	8
4.2	INSURE ELECTRICAL SPECIFICATION	8
4.3	ELECTRICAL CONTROLS	8
4.4	ELECTRICAL CONNECTIONS/ HIGH VOLTAGE	8
4.5	24V DC VOLTAGE FROM PUMP CONTROLLER	9
5.	Standard wiring diagrams for MicroCool® IBEX pump modules	9
6.	Principle of the VFD system on the IBEX pump unit	10
6.1	VARIABLE FREQUENCY DRIVE	10
7.	MicroCool IBEX - STARTING THE SYSTEM	10
7.1	START UP	10

8.	PRESSURIZING THE SYSTEM	11
9.	System Operation	12
	Time Clock.....	12
9.1	SETTING DATE & TIME.....	12
9.2	SETTING AUXILIARY PARAMETERS.....	13
	Drain/Pressure Relief Valve Time	13
9.3	SETTING DRAIN VALVE TIME	13
	24 Hour, 7 Day Clock Time	13
9.4	SETTING 24 HOUR, 7 DAY CLOCK TIMERS.....	13
9.4	SETTING CYCLE/PULSE TIMER.....	14
9.5	DISABLING F1 "MANUAL RUN".....	14
9.6	SETTING INTERNAL TEMPERATURE AND HUMIDITY CONTROLS (OPTIONAL UPGRADE).....	14
9.7	SETTING FOR HUMIDITY CONTROL ONLY:.....	15
9.8	SETTING FOR TEMPERATURE CONTROL ONLY.....	15
9.9	SETTING FOR HUMIDITY CONTROL WITH TEMPERATURE OVERRIDE:.....	15
9.10	SETTING FOR TEMPERATURE CONTROL WITH HUMIDITY OVERRIDE.....	15
9.11	TO VIEW THE VFD FAULT CODE.....	15
10.	SYSTEM MAINTENANCE	21
10.1	CRANKCASE OIL	21
	ISO-68 HYDRAULIC MINERAL OIL IS RECCOMENDED FOR ALL APPLICATIONS	21
	Figure 20 – Crankcase Oil Levels.....	21
10.2	ELECTRICAL MOTOR SERVICE	21
10.3	INLET WATER FILTERS.....	22
10.4	ATOMIZATION LINES/MANIFOLD HOSES.....	22
10.5	SYSTEM FLUSH – SHUT DOWN - WINTERIZING	22
10.6	INLET WATER PRESSURE SWITCH.....	22
10.7	OPTIONAL EXTRAS.....	23
11.	TROUBLE SHOOTING	24
11.1	PUMP MODULE HAS STOPPED RUNNING	24
11.2	INLET WATER PRESSURE FAULT.....	24
11.3	VARIABLE FREQUENCY DRIVE (VFD) FAULT CODES.....	25
12.	WARRANTY.....	27
13.	UL CERTIFICATION.....	29

14.	IBEX 4-11 GALLON ILLUSTRATIONS	30
14.1	IBEX 4-11 GALLON FRONT VIEW.....	30
14.2	IBEX 4-11 GALLON REAR VIEW	31
14.3	IBEX 4-11 GALLON RIGHT SIDE VIEW.....	32
14.4	IBEX 4-11 GALLON LEFT SIDE VIEW	33
14.5	IBEX 4-11 GALLON TOP VIEW	34
14.6	IBEX 4-11 GALLON TOP INTERNAL VIEW	35
14.7	IBEX 4-11 GALLON BOTTOM VIEW	36
14.8	IBEX 4-11 GALLON 240V CONTROL PANEL.....	37
14.9	IBEX 4-11 GALLON 380-575V CONTROL PANEL	38
14.10	IBEX 4-11 GALLON NOTES 1.....	39
14.11	IBEX 4-11 GALLON NOTES 2.....	40
14.12	IBEX 4-11 GALLON 208-240V ELECTRICAL DIAGRAM.....	41

WARNING!!

PLEASE TAKE NOTE OF THE FOLLOWING

1. BEFORE STARTING

PLEASE READ THIS GUIDE ENTIRELY BEFORE BEGINNING INSTALLATION

ALSO, READ SUPPLEMENTAL INFORMATION RELATING TO OPTIONAL CONTROL EQUIPMENT

1.1 CRANKCASE OIL PLUG

The pump module crankcase vent has been plugged to prevent accidental oil leakage during shipment. Remove the plug and replace it with the supplied vent cap before operating the pump unit. **FAILURE TO DO SO WILL CAUSE OIL LEAKS.**

1.2 OIL LEVEL

Check that the oil level appears 1/2 way in the sight gauge or within range on the dipstick in the pump head.

1.3 INLET WATER SUPPLY PRESSURE.

When the pump module is running, it must be supplied with an inlet water supply of

NEVER LESS THAN 20 P.S.I. (1.40 BAR) AND NEVER MORE THAN 90 P.S.I. (6.20 BAR)

- *INLET WATER SUPPLY PRESSURE SHOULD BE STEADY AND SHOULD NOT BE ALLOWED TO FLUCTUATE OUTSIDE OF THESE RANGES. FAILURE TO DO SO CAN RESULT IN DAMAGE TO EQUIPMENT AND IS NOT COVERED BY WARRANTY.*
- *IF WATER PRESSURE DROPS BELOW 20 PSI, THE PUMP WILL SHUT OFF AND THE FAULT LIGHT WILL COME ON. SEE SECTION 9 SYSTEM OPERATION FOR FUTURE INFORMATION.*

1.4 OIL CHANGE INTERVAL

The crankcase oil must be changed after the first **50 hours** of operation and from then on, once every **500 hours**.

- *ISO-68 HYDRAULIC MINERAL OIL IS RECOMMENDED FOR ALL APPLICATIONS*
- *SECONDARY CHOICE SAE-20 CRANKCASE MINERAL OIL MAY BE USED FOR ALL APPLICATIONS*

1.5 HIGH PRESSURE FITTINGS

The system operates at 1,000 P.S.I. (70 bar) and should always be shut down when working on fittings or manifold line. Extreme caution should always be exercised when working with high pressure water. Always wear safety glass when working around fog equipment.

1.6 INLET WATER SUPPLY PLUMBING MATERIAL

Only rated and approved brass fittings or stainless-steel fittings should be used to make plumbing connections. The use of **galvanized or steel pipe fittings** can cause system failure, nozzle blockage and pump damage, and may void warranty.

1.7 FLUSHING THE SYSTEM

Before pressurizing the system, flush all plumbing and atomization lines thoroughly to purge any residual debris. Please refer to the startup section 7 of this manual.

1.8 TEFLON TAPE

When using Teflon tape on NPT threads, leave 1 or 2 of the starting threads showing. This will prevent pieces of Teflon tape from entering the system, which could cause blockage or damage.

WATER QUALITY

2. WATER QUALITY

To obtain the best performance, special consideration should be given to the quality of water used in a MicroCool fog system. For more information about Water Quality, consult a MicroCool specialist.

MicroCool® IS NOT RESPONSIBLE FOR NOZZLE BLOCKAGE DUE TO POOR WATER QUALITY.

2.1 TOTAL DISSOLVED SOLIDS COUNT

Water with total dissolved solids (TDS) counts of greater than 500 parts per million (PPM), water with high calcium and magnesium carbonate levels, or water with pH levels below 6.7 and above 7.5, may not be satisfactory and could lead to excessive nozzle blockage and the need for nozzle maintenance.

2.2 WATER ANALYSIS

If there is any doubt about water quality, a water analysis is recommended. Of major interest is the water's Langelier Saturation Index (SLI) together with other items such as hardness and TDS. A slightly negative, or neutral, Langelier index is preferred, whereas a positive index may indicate a tendency to form calcium carbonate deposits in the lines and nozzles. If using city water, an analysis should be available from the city/town water department. If in any doubt, please contact your MicroCool representative for further information.

2.3 WATER TREATMENT

Generally speaking, most municipal water is suitable for atomization. Well water, river water and the like should be tested before atomizing. If an analysis indicates any unusually high levels of undesirables, proper treatments are available. MicroCool® can supply a variety of water treatment systems. Please contact MicroCool® for further details.

2.4 ULTRAVIOLET WATER PURIFIERS

Optional ULTRAVIOLET high intensity light purifiers can also be installed on the inlet water supply to sterilize the system water. By bombarding the water with UV light, dangerous pathogens, spores, and germs are destroyed. UV systems must be regularly serviced to maintain the correct high intensity output.

2.5 REVERSE OSMOSIS WATER TREATMENT

MicroCool offers optional comprehensive reverse osmosis packages for all applications. Units are available for large scale industrial as well as domestic installations.

Reverse Osmosis units incorporate a semi-permeable membrane that micro-filters the water to 0.0001 microns removing bacteria, viruses, aqueous salts and metal ions. By eliminating these from the supply water, MicroCool ensures that clean, hygienic water is used in each system. Clean water will also reduce nozzle blockage, foul odors, and white "chalky" deposits on material close to the fog spray.

MicroCool reverse osmosis systems are designed specifically for each application. Please consult with MicroCool specialists for more details.

3. INSTALLATION OF THE PUMP MODULE

Installation Procedure:

- Determine pump module location.
- Identify water supply/connection for the system.
- Determine routing of the high-pressure manifold from the pump.
- Establish drainage location from the pump.
- Verify correct electrical power supply to the pump.
- Determine all the above for optional Equipment - Zone Controllers, Temperature/Humidity Controllers, Reverse Osmosis, UV sterilizers, etc...

3.1 POSITIONING THE PUMP MODULE

The pump module requires a flat level surface. Position selection will largely depend on the availability of power and water, but remember the points outlined on the previous pages as the terms of the pump warranty depend upon it.

A concrete floor or a concrete slab is ideal. Attach the supplied adjustable feet and plugs to the legs of the pump as shown in the photograph (right). Using a level, make sure that the IBEX unit sits as level and plumb as possible.



3.2 WATER SUPPLY AND CONNECTION

The water supply should be capable of 1.5 times the maximum flow of the pump as shown in the table below.

Pump Model & Flow	MIN Flow rate (USGPM)	MIN Flow Rate (LPM)	MIN Pressure psi / bars
IBEX 4000 (4.40gpm)	6.60	25.00	20 / 1.40
IBEX 5000 (5.00gpm)	7.5	28.00	20 / 1.40
IBEX 6000 (6.00gpm)	9	34.00	20 / 1.40
IBEX 8000 (8.00gpm)	12	45.00	20 / 1.40
IBEX 11000 (11.00gpm)	16.50	63.00	20 / 1.40

Correct water pressure and flow rate are essential to pump operation. All pump modules require a minimum of 20 P.S.I. (1.40 BAR) and a maximum of 90 P.S.I. (6.20 BAR) while in operation. The pressure should always be constant and not fluctuate outside these ranges, especially on system start up. All pump modules are equipped with a low-pressure inlet water fault delay timer, which allows small drops in pressure, but will ultimately "fault off" if low pressure is present for more than a few seconds.

Ensure that either copper or PVC pipe is used to provide the correct water supply to the IBEX unit. Never use steel or galvanized steel fittings. Always use the largest diameter pipe practical.



3.3 DRAINAGE FROM THE PUMP

After the pump module shuts down, the water remaining in the manifold lines will drain out through the pump module and through the end of the atomization lines on some lines. Ensure that the drain outlet is routed to a suitable drainage point to avoid flooding. A 6 foot (1.8 M) low pressure drain tube is provided for this purpose. This hose can be extended as necessary.

4. **PUMP MODULE POWER SUPPLY**

After all water and plumbing connections have been completed, a licensed, qualified electrician should connect the power supply to the pump. It is important to follow the National Electrical Code (NEC), as well as any local codes to ensure a safe installation.

4.1 **CAUTION!**

If the pump unit will be powered by a generator at any time, a properly sized line reactor needs to be installed prior to the pump unit to eliminate voltage spikes. If this is not done, the Variable Frequency Drive (VFD) & processor could be damaged and the warranty may be voided.

4.2 INSURE ELECTRICAL SPECIFICATION

Establish that the circuit to be used to power the pump module is of the same electrical specification as the pump module. The IBEX electrical specification can be found on the serial number label or from the electrical wiring diagram adhered to the inside cover of the electrical enclosure on the pump module.

- 4.2.1 The circuit to the pump module must be dedicated and properly sized to carry the electrical load placed upon it by the pump motor. Please refer to the MicroCool® Engineering Manual or electrical data plate on the motor to determine the amperage draw of the Ibx pump module.
- 4.2.2 The power supply to the pump module must be hard wired directly to a fused disconnect box. If the power supply cannot be directly wired to a disconnect box, then it should be hard wired, using a junction box, into a suitable circuit with a disconnect box located elsewhere. This applies to either single phase or three phase applications.
- 4.2.3 After verifying all the above, power should be taken from the disconnect box/junction box to the terminal strip located inside the electrical enclosure mounted on the pump module. We recommended that the correct sized wiring be in conduit (preferably liquid tight); make the final connection to the high voltage terminal strip.

4.3 ELECTRICAL CONTROLS

The high voltage motor electrical supply must be connected to the pump module inside the control box. The low voltage control wiring must also be connected inside the control box. We recommend that a LICENSED ELECTRICIAN IS USED FOR ELECTRICAL CONNECTIONS.

4.4 ELECTRICAL CONNECTIONS/ HIGH VOLTAGE

Open front cover to connect the high voltage wiring to pump controls. Connect high voltage to TB1 (terminal block 1) electrical strip in the control box. There is a conduit connector provided for connecting conduit to the side of the control box.

208-240 volt 1 phase 50/60 Hz systems connect to:

Connections:

- 1: Zero Voltage Remote Start (cable must be shielded)
- 2: Zero Voltage Remote Start (cable must be shielded)
- 3: Zero Voltage Fault output
- 4: Zero Voltage Fault output
- 5: 208-240 Volt 1 phase 50/60 Hz power supply- L1
- 6: 208-240 Volt 1 phase 50/60 Hz power supply- L2
Ground grnd(grn/yel)

208-240 volt 3 phase 50/60 Hz systems connect to:

Connections:

- 1: Zero Voltage Remote Start (cable must be shielded)
- 2: Zero Voltage Remote Start (cable must be shielded)
- 3: Zero Voltage Fault output
- 4: Zero Voltage Fault output
- 5: 208-240 Volt 3 phase 50/60 Hz power supply- L1
- 6: 208-240 Volt 3 phase 50/60 Hz power supply- L2
- 7: 208-240 Volt 3 phase 50/60 Hz power supply- L3
Ground grnd(grn/yel)

See note 4.5

380-575 volt 3 phase systems connect to:

PD1 - Connections:

- L1: 380-575 Volt 3 phase 50/60 Hz power supply- L1
- L2: 380-575 Volt 3 phase 50/60 Hz power supply- L2
- L3: 380-575 Volt 3 phase 50/60 Hz power supply- L3

TB1 - Connections:

- 1: Zero Voltage Remote Start (cable must be shielded)
- 2: Zero Voltage Remote Start (cable must be shielded)
- 3: Zero Voltage Fault output
- 4: Zero Voltage Fault output
Ground grnd(grn/yel)

4.5 24V DC VOLTAGE FROM PUMP CONTROLLER

External (remote) start connections must be made to TB1 Terminals 1 & 2. Note that this connection is powered by a **24V DC voltage from the pump controller**. Adequate care must be taken NOT to connect a different or separate power supply to these terminals as serious damage could occur. If in doubt – please contact the factory for a suitable relay or conditioner.

WARNING: The control box is completely wired for immediate operation. After high voltage wiring is connected and the unit is supplied with proper water pressure, pressing F1 will immediately activate the pump operation.

5. **Standard wiring diagrams for MicroCool® IBEX pump modules**

An as-built wiring diagram has been added to the back of this manual.

6. Principle of the VFD system on the IBEX pump unit

6.1 VARIABLE FREQUENCY DRIVE

A VFD (Variable Frequency Drive) controls the speed of the electrical motor (and subsequently the pump head) by changing the Frequency (Hertz). The IBEX pump module has a Pressure Transducer unit mounted on the high-pressure (discharge) side of the pump that transmits the water pressure back to the control unit.

- 6.1.1 The controller is pre-set to maintain a pressure of 1,000 psi (70 Bar) at the discharge of the pump.
- 6.1.2 As the water flow rate of the system changes (for example with more or less nozzles in operation) the controller will increase or decrease the motor speed to maintain the required pressure (1,000 psi / 70 Bar). The controller is capable of increasing the speed (frequency) to a maximum of 50 Hz. The rate of change is governed by programming within the drive to reduce motor, pump, and equipment wear.
- 6.1.3 The minimum speed of the motor is also regulated by the controller. At very low rpm, the pump may be moving too slowly to adequately distribute the oil in the pump reservoir. Damage to the pump may occur. The minimum speed (frequency) is set at 15 Hz to protect the pump unit from oil starvation.
- 6.1.4 For more details on the VFD drive, the readings and fault status, refer to the WEG Drive supplement at the end of this manual.

7. MicroCool IBEX - STARTING THE SYSTEM

7.1 START UP

- 7.1.1 Install UV bulb prior to start up. (If UV is provided)
- 7.1.2 The system must be primed and flushed before pressurization. This removes any contaminants such as dirt, brass filings or Teflon tape that have found their way into the system.
- 7.1.3 Turn on the water supply to the pump module. The inlet or low-pressure gauge should read at the very least 20 PSI (1.4 BAR) indicated by the green area of the dial. If the water pressure is not sufficient, do not try to start the pump. The water pressure problem must be corrected first.
- 7.1.4 To prime the pump module, turn on the power supply to the IBEX module, open the electrical enclosure, switch the circuit breaker to the on position. Once the VFD indicates "RDY" and the PLC is illuminated, press F3 and F4 simultaneously. This will start the prime sequence of 30 seconds. The pump is now ready to be started.
- 7.1.5 To start the IBEX module press F1 (run in Manual). The pump module will now run, there must be always between 20 PSI (1.4 BAR) and 90 PSI (6.2 BAR) of pressure available to the pump. Note- should the water pressure drop below the factory preset of 20 PSI, there is a 3 second delay before the system goes to "FAULT". Refer to section 9 to reset.
- 7.1.6 The pump motor RPM will ramp (increase) up to the maximum speed (50 Hz) to fill the system. Do not worry if the pressure does NOT reach 1,000 PSI (70 BAR) at this time (during flush sequence).
- 7.1.7 Let the module run for 2-3 minutes making sure that there is a good flow of water running out the end of the atomization lines. Lines may have to be flushed in groups, with larger systems, to ensure adequate system flush.
- 7.1.8 When finished flushing, press F3 (Stop) to stop the pump module.
- 7.1.9 The system is now flushed and ready for the pressurization procedure.

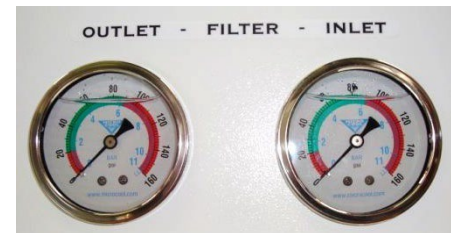

8. PRESSURIZING THE SYSTEM

8.1 ABOUT PRESSURE REGULATOR

The regulator is set as a safety valve should the system pressure exceed IBEX: 1,100 PSI. At extremely low flow, the regulator will bypass water back into the pump head as the VFD drive has reached its minimum Frequency (Hertz).

8.2 PROCEDURE TO RESET THE PRESSURE REGULATOR

ABOUT THE PRESSURE REGULATOR: ADJUSTMENTS SHOULD NOT BE MADE TO REGULATOR. ONLY FOLLOW THIS RESET PROCEDURE IF REGULATOR IS REPLACED OR WHEN REPLACING PUMP HEAD.

Safety glasses must be worn when adjusting pressure. Always keep guards and covers in place.

NEVER DISASSEMBLE THE REGULATOR UNDER PRESSURE!!!

If for any reason the regulator is adjusted, or changed, follow this procedure to reset the correct adjustment.

1. Press F3 (IBEX) to turn off the pump.
2. Turn off the electrical supply at the disconnect switch to electrically isolate the pump.
3. Locate the pressure transducer and unplug the electrical lead by squeezing the clip.
4. Restore the power and start the unit by pressing F1.
5. Adjust the regulator by turning* clockwise or counterclockwise until the pressure gauge indicates 1,100 psi (75.8 Bar) for IBEX. When the pressure is steady at 1,100 make sure that the "Jam Nut" is tightened to lock the adjustment in position. [***Clockwise**: increase pressure. **Counterclockwise**: decrease pressure.]
6. Press F3 (IBEX) to stop the pump, shut off power. Plug electrical lead back into transducer, restore electrical power.
7. See Manual for 'PRESSURIZING SYSTEM'. Once the maximum pressures are achieved (above), system will fall back and maintain pressure **IBEX: 1,000 PSI**.

Example: Pressure regulator assembly.



Example: Pressure regulator assembled on pump head.

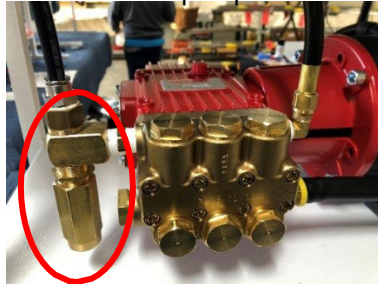

Example: Pressure regulator assembled on pump head.

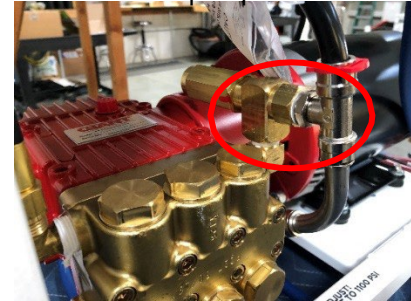

IBEX: Where to locate pressure transducer underneath pump.



Locate transducer underneath pump.

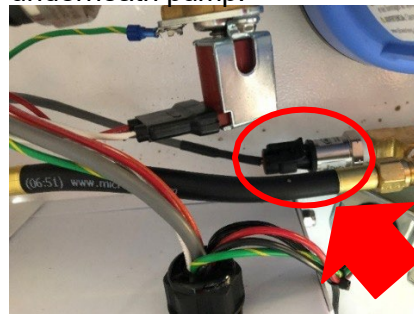

9. System Operation

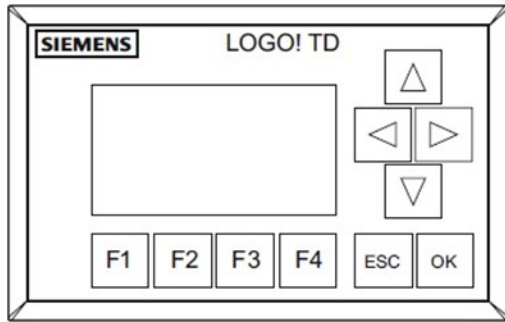

- F1 – Manual Run
- F2 – Auto Ready
- F3 – Stop/Reset
- F4 – Use to access parameter settings (hold for 3 seconds)
- ESC – Exit existing screen
- OK – Enter/Save

F1 – MANUAL RUN

F1 operates the pump manually, the pump will run continuously regardless of external controllers or internal time settings. F1 should be disabled if the system design requires the pump to be operated by zone controllers, external controllers, or internal time clocks. See 9.6 *Disabling F1 “Manual Run”*

F2 – AUTO READY

F2 puts the pump in automatic mode and requires a hard-wired input (switch) into the electrical control panel on terminal 1 & 2 on TB1 (yellow and blue terminal blocks). Auto mode is also used if the internal 24-hour, 7 day clocks and/or internal temperature and humidity controllers are to be activated.

Note: If the internal controls are to be used and no remote switch is installed, then the supplied jumper is to be installed between terminal 1 & 2 on TB1.

F3 – STOP/RESET

F3 is the stop and reset input. This button will stop the pump module and reset all faults.

F4 – PARAMETERS, SETTINGS & PUMP DETAILS

Holding F4 in for 3 seconds will bring up the pump details which include: Model number, Serial number, Manufacture date and PLC Program version. This screen will stay visible for 30 seconds. The parameter settings are also accessible from this screen. See 9.1 and 9.2

Time Clock

The internal time clock needs to be set to the correct local time.

9.1 SETTING DATE & TIME

1. Press and hold F4 for three seconds.
2. Display screen will change to the day, time and date.
3. Press “ESC” once.
4. Display screen will indicate “Stop”, “Program”, “Setup”, “Diagnostics” and “Network” with “>” indicating selection.
5. Use the ▲&▼ buttons to move the >selection indicator to “>Setup” and press OK.
6. Use the ▲&▼ buttons to move the >selection indicator to “>Clock.” and press OK.

7. Use the ► & ◀ buttons to move the cursor and the ▲ & ▼ buttons to change the value.
8. Once the value is changed move the cursor to the next value.
9. Set the date and time and press OK to save.
10. Press “ESC” to exit the current menu.
11. To exit the menus completely, press the “ESC” until day, time and date is displayed and press the ▲ button.
12. The display will return to the home screen.

9.2 SETTING AUXILIARY PARAMETERS

- 1. Auxiliary features only operate in “Auto” (F2)**
2. The Ibex pump system has internal features that can be activated if required. The features consist of a drain valve timer, three, 24-hour, 7-day clock timers, cycle/pulse timer, temperature, and humidity control (optional upgrade)
3. To access and activate these features follow the steps bellow:
4. Press and hold F4 for three seconds.
5. Display screen will change to the day, time and date.
6. Press “ESC” once.
7. Display screen will indicate “Stop”, “Set Param”, “Msg Config” and “Set..” with “>” indicating selection.
8. Use the ▲ & ▼ buttons to move the >selection indicator to “>Set Program” and press OK.
9. Use the ▲ & ▼ buttons to move the >selection indicator to “>Set Parameters” and press OK.
10. Using the ▲ & ▼ buttons to move through the menu until you get to required option and press OK.
11. Use the ► & ◀ buttons to move the cursor and the ▲ & ▼ buttons to change the value.
12. Once the value is changed move the cursor to the next value.
13. To save the changes press the “OK” button once.

Drain/Pressure Relief Valve Time

The drain/pressure relief valve time is the time setting that determines how long the drain valve remains open after the pump unit shuts down. This valve can be used to only relieve the nozzle line pressure or relieve the nozzle line pressure and drain the system. If only pressure relief is required then a short time of 10 – 15 seconds is adequate, if the system is required to drain completely then a longer time setting would be required, depending on the system size and length of manifold lines.

9.3 SETTING DRAIN VALVE TIME

1. The following feature is available in “Set Param” and is labeled as “DRAIN T” the default drain time setting is 30 seconds.
2. To access and increase or decrease the drain time, follow the steps in 9.2 "Setting Auxiliary Parameters"

24 Hour, 7 Day Clock Time

The controller contains three 24-hour 7-day time clocks that can be set to start and stop the pump unit on pre-set days and times as required. Special care should be taken so as not to not program conflicting times.

9.4 SETTING 24 HOUR, 7 DAY CLOCK TIMERS

1. The following feature is available in “Set Param” and is labeled as “WEEK T 1”, “WEEK T 2”, “WEEK T 3”. The default setting is “OFF”.
2. Again, special care should be taken when programing this feature to avoid conflicting times between the three different timers.
3. To access and set the timer, or timers, follow the steps in 9.2 "Setting Auxiliary Parameters."
4. To enable the 7-day 24-hour timer feature, the “CLOCK TMR” “Switch=off” needs to be set to “Switch=on.”

5. Set the days of week, the “ON” (start) time and the “OFF” (stop) TIME.

6. The pump system will only operate within the set times in “Auto.”

Note: If there is no remote switch required in the system, the supplied jumper needs to be installed between terminal 1 & 2 on TB1 (Yellow & Blue terminal block)

Cycle/Pulse Timer

The cycle/pulse timer will cycle the pump on and off based on the time settings in the timer, TH represents on time and TL represents the off time.

9.4 SETTING CYCLE/PULSE TIMER

1. The following feature is available in “Set Param” and is labeled as “CYCLE T” the default setting is 1 minute on and 1 minute off but is disabled.
2. To access, enable and set cycle/pulse times, follow the steps in 9.2 “Setting Auxiliary Parameters.”
3. To enable the cycle timer feature the “CYCLE” “Switch=off” needs to be set to “Switch=on.”
4. “CYCLE T” settings are represented as “TH” as on time and “TL” as off time.
5. The cycle/pulse feature will cycle/pulse the pump module while operating in “Auto.”

CAUTION-do not set the off-cycle time shorter than 1 minute in order to avoid motor heating.

9.5 DISABLING F1 “MANUAL RUN”

If the system includes zone controllers or zone valves, and is run in Auto, F1 should be disabled. By disabling F1, the pump system has to be started and stopped by a remote input from a zone controller, or another control device, and the pump would be in “Auto Ready” (press F2).

WARNING, operating the pump unit in F1 “Manual Run” with zone controllers or zone valves installed in the system, could cause the pump to dead-head resulting in damage to the pump unit that would not be covered under warranty.

1. F1 disable is located in “Set Param” and is labeled as “F1 DISAB” the default setting is off. The soft key settings represent:
 - a. Off = F1 is enabled
 - b. On = F1 is disabled
2. To access, enable and set F1 operation, follow the steps in 9.2 “Setting Axillary Parameters.”

9.6 SETTING INTERNAL TEMPERATURE AND HUMIDITY CONTROLS (OPTIONAL UPGRADE)

1. If this upgrade was ordered with the system, temperature and humidity control will be available in the controller.
2. To access, enable and set the temperature and humidity control. Follow the steps in “Setting Auxiliary Parameters.”
3. To enable the temperature and humidity control, “TEMP & HUM” switch needs to be set from “Switch=off” to “Switch=on”.
4. “HUMID SP” represents the humidity set point. To enter the set point, set the “off=***” to required humidity level and set “on=***” to 0%. Example: if required humidity set point is 35%, set “off= 35” and “on= 0”.
5. “TEMP SP” represents temperature set point, to enter the set point, set the “off=***” to required temperature level in F°/C° and set “on=***” to at least 3° points above “off=***” setting. The difference between the on and off setting is the hysteresis or dead band. Example: if required temperature set point is 75°F with a 3°F dead band set “off=75” and “on=78”.
6. The temperature and humidity outputs are in series, so both the temperature and humidity contacts need to be closed for the system to run.
7. To view current temperature and humidity levels and set points, press “F4” once. The display will revert to the operation screen after 30 seconds.

9.7 SETTING FOR HUMIDITY CONTROL ONLY:

1. Set the temperature set point to 33°F/0°C “off=33°F/1°C” and “on=34°F/1°C”. (This forces the temp contact.)
2. Set the humidity set point to desired humidity to be maintained as described above.
3. The controller will start the pump system when the humidity drops below the set point.

9.8 SETTING FOR TEMPERATURE CONTROL ONLY:

1. Set the humidity set point to 100%. (This forces the humidity contact).
2. Set the temperature set point to the desired temperature to be maintained as described above.
3. The controller will start the pump system when the Temperature drops below the set point.

9.9 SETTING FOR HUMIDITY CONTROL WITH TEMPERATURE OVERRIDE:

1. Set the humidity set point to desired humidity to be controlled as described above.
2. Set the temperature set point to desired temperature, not to go below as described above.
3. The controller will start the pump system when the humidity drops below the humidity set-point but will stop the pump if the temperature drops below temperature set point.

9.10 SETTING FOR TEMPERATURE CONTROL WITH HUMIDITY OVERRIDE:

Set the temperature set point to desired temperature as described above.

Set the humidity set point to humidity level not to exceed as described above.

The controller will start the pump system when the temperature rises above the set point but will shut the pump system off when the humidity set point is reached.

9.11 TO VIEW THE VFD FAULT CODE:

All 380V to 575V IBEX pump units are installed with a panel door disconnect. In order to view status information on the VFD display, it is necessary to defeat the door switch mechanism, and to open the door in the ON position.

CAUTION! Opening the panel door in this manner does not remove power from the internal electrical circuits.

1. First turn the black panel latch counterclockwise to release.
2. Using a flat screwdriver turn the black screw release counter clockwise about 1/8” and hold it in that position.
3. Pull the door open with the red disconnect switch in the vertical position.
4. Once the inspection is complete, close the panel door by simply holding the red disconnect switch in the vertical position, push the door closed, and re-latch the black door latch.



MicroCool® IBEX Pump Information Screens

<pre style="font-family: monospace; font-size: 0.9em;"> MicroCool® IBEX PUMP MODULE www.microcool.com TEL: +17603221111 RUN HOURS 0 h 0 m Fr 13:36 2016-05-27 </pre>	<h3 style="text-align: center;">Home Screen</h3> <ul style="list-style-type: none"> MicroCool Pump Software version Hours of operation
<pre style="font-family: monospace; font-size: 0.9em;"> MicroCool® IBEX KEYPAD FUNCTIONS F1>RUN-MANUAL F2>AUTO-READY F3>STOP & RESET F4>SETTINGS </pre>	<h3 style="text-align: center;">Keypad Functions</h3> <ul style="list-style-type: none"> F1- Press to run manual F2- Press to run in auto (requires external contact) F3- Stop/ Reset F4- Hold for 3 seconds to enter parameter settings
<pre style="font-family: monospace; font-size: 0.9em;"> MicroCool® IBEX MODEL # IBX***** SERIAL # 17-***** MFG DATE JAN2017 SOFTWARE V15.01 VERSION IMPERIAL </pre>	<h3 style="text-align: center;">Data Plate</h3> <ul style="list-style-type: none"> Press and hold F4 for 3 seconds. The pump detail display will remain visible for 30 seconds. Model number. Serial number. Manufacture date. PLC software version.
<pre style="font-family: monospace; font-size: 0.9em;"> MicroCool® IBEX MODE » MANUAL STATUS » RUN STOP » PRESS F3 PRESSURE 1001 PSI RUN HOURS 0 h 0 m </pre>	<h3 style="text-align: center;">Manual Run</h3> <ul style="list-style-type: none"> Pump is running "RUN" Manual System pressure Hours of operation
<pre style="font-family: monospace; font-size: 0.9em;"> MicroCool® IBEX MODE » AUTO STATUS » READY STOP » PRESS F3 PRESSURE 0 PSI RUN HOURS 0 h 3 m </pre>	<h3 style="text-align: center;">Auto Ready</h3> <ul style="list-style-type: none"> Pump is "Auto Ready" to run (requires external contact to run) System pressure Hours of operation
<pre style="font-family: monospace; font-size: 0.9em;"> MicroCool® IBEX MODE » AUTO STATUS » RUN STOP » PRESS F3 PRESSURE 1001 PSI RUN HOURS 0 h 1 m </pre>	<h3 style="text-align: center;">Auto Run</h3> <ul style="list-style-type: none"> Pump is in "Auto Run" System Pressure Hours of Operation

<pre> MicroCool® IBEX MODE » AUTO 1 SHOT STATUS » RUN 26:68s STOP » PRESS F3 PRESSURE 1001 PSI RUN HOURS 0h 0m </pre>	<p style="text-align: center;">One Shot Run</p> <ul style="list-style-type: none"> • Pump is running in “Auto” mode. • One shot timer is active and counting down. • System pressure. • Hours of operation
<pre> MicroCool® IBEX CONTROL PARAMETERS TEMPERATURE 72 °F TEM SETPOINT 80 °F HUMIDITY 46 % HUM SETPOINT 45 % </pre>	<p style="text-align: center;">Control Parameters</p> <ul style="list-style-type: none"> • Current temperature • Temperature set point • Current humidity • Humidity set point <p>*Only active when temp and humid soft key is set to ON in “parameter set” (only available with optional upgrade)</p>
<pre> MicroCool® IBEX MODE » AUTO STATUS » RUN HUMIDITY 45 % TEMPERATURE 72 °F PRESSURE 1001 PSI </pre>	<p style="text-align: center;">Auto Run Control Parameters</p> <ul style="list-style-type: none"> • Pump is running in AUTO • System pressure • Current humidity • Current temperature <p>*Only active once temp and humid soft key is set to ON in “parameter set” (only available with optional upgrade)</p>
<pre> MicroCool® IBEX *PUMP PRIME & FLUSH* TIME 30:00s ELAPSED TIME 25:02s </pre>	<p style="text-align: center;">Prime/Flush</p> <ul style="list-style-type: none"> • Pump system is in Prime or Flush sequence • Prime/Flush Time • Elapsed Time
<pre> MicroCool® IBEX MODE » AUTO CLOCK STATUS » RUN STOP » PRESS F3 PRESSURE 1001 PSI RUN HOURS 0h 1m </pre>	<p style="text-align: center;">Auto Clock Run</p> <ul style="list-style-type: none"> • Pump is running “RUN” in auto time clock • System pressure • Hours of operation

<pre> MicroCool® IBEX * PRESSURE RELIEF * DRAIN TIME 30:00s ELAPSED TIME 01:72s PRESSURE 550 PSI </pre>	<p style="text-align: center;">Pressure Relief</p> <ul style="list-style-type: none"> • Pump has stopped and is draining • System pressure • Drain Time
<pre> MicroCool® IBEX MODE » AUTO CYCLE STATUS » RUN 00:50m STOP » PRESS F3 PRESSURE 1001 PSI RUN HOURS 0h 5m </pre>	<p style="text-align: center;">Auto Cycle Run</p> <ul style="list-style-type: none"> • Pump is running on cycle time • On timer • System pressure • Hours of Operation
<pre> MicroCool® IBEX MODE » AUTO STATUS » START DELAY DELAY TIME 06:00s START IN 02:94s RUN HOURS 0h 0m </pre>	<p style="text-align: center;">Auto Start Delay</p> <ul style="list-style-type: none"> • Auto Start Active • Start Delay • Delay Time • Hours of Operation

<pre> MicroCool® IBEX ** FAULT ** LOW INLET PRESSURE RESTARTS > 4 1 RESTART DELAY 30:00s RESTART IN 27:32s </pre>	<p style="text-align: center;">Inlet Pressure Fault</p> <ul style="list-style-type: none"> • Inlet water pressure dropped below safe operating limit • 30 second restart delay is in process • If water pressure is restored within 30 second delay, pump will start up and operate normally • If water pressure is not restored, another 30 second delay will start • Pump will attempt to restart 4 times before the system locks out on a fault
<pre> MicroCool® IBEX ** FAULT ** FREQUENCY INVERTER RESTARTS > 4 1 RESTART DELAY 30:00s RESTART IN 17:29s </pre>	<p style="text-align: center;">Frequency Inverter Fault</p> <ul style="list-style-type: none"> • Pump system has faulted on VFD fault • 30 second restart delay is in process. • If VFD fault is cleared within 30 seconds pump will restart and operate normally. • The pump will attempt to restart 4 times before the system locks out on a fault.
<pre> MicroCool® IBEX * SERVICE REQUIRED * OIL CHANGE SYNTHETIC OIL 75W-90 PRESS F4 THREE TIMES TO RESET DISPLAY </pre>	<p style="text-align: center;">Service Oil Change</p> <ul style="list-style-type: none"> • Pump requires service. • Change pump oil – (Please dispose of used oil in accordance with local laws and regulation). • Press F4 key 3 times consecutively to reset
<pre> MicroCool® IBEX F1>RUN-MANUAL BUTTON IS DISABLED TO ENABLE F1 BUTTON GO TO SETTINGS AND SET "F1 DISAB" OFF </pre>	<p style="text-align: center;">Manual Disabled</p> <ul style="list-style-type: none"> • F1 button disabled • Settings to enable
<pre> MicroCool® IBEX * SERVICE REQUIRED * CHANGE OUT LAMP IN ULTRAVIOLET FILTER PRESS F4 THREE TIMES TO RESET DISPLAY </pre>	<p style="text-align: center;">Service UV Lamp</p> <ul style="list-style-type: none"> • Change UV lamp • Press F4 three times to rest.

```

MicroCool® IBEX
** FAULT LOCKOUT **
LOW INLET WATER
PRESSURE
» RESTORE PRESSURE
» PRESS F3 TO RESET

```

Lockout Fault- Inlet Pressure

- Pump system has faulted out on a low water pressure fault.
- Restore water pressure to the pump.
- Press F3 to reset

```

MicroCool® IBEX
** FAULT LOCKOUT **
HIGH WATER
TEMPERATURE
* CHECK ZONE VALVES
PRESS F3 TO RESET

```

Lockout Fault – High Water Temp.

- Pump system has faulted on high water temperature fault.
- This fault is typically caused by dead heading the pump by running it in “Manual” with zone valves closed, see point 9.6.
- Check that all zone valves are operating correctly and are in “Auto”
- Press F3 to reset, if fault does not clear activate the prime and flush sequence by pressing F3 and F4 simultaneously. This will flush the pump system with cool supply water. Once it is complete Press F3 to clear fault. If the fault does not clear, repeat the flush process.
- Note: The fault will only clear once the temperature of the system has dropped below 101°F/38°C.

```

MicroCool® IBEX
** FAULT LOCKOUT **
FREQUENCY INVERTER
SEE FAULT CODE
REFERENCE VFD MANUAL
PRESS F3 TO RESET

```

Lockout Fault – Frequency Inverter

- Pump system has faulted on VFD fault
- Reference manual with fault code on VFD
- Once cleared press **F3** to reset

```

MicroCool® FOCUS
** FAULT LOCKOUT **
HIGH OUTLET WATER
PRESSURE
* CHECK REGULATOR
* PRESS F3 TO RESET

```

Lockout Fault - High Outlet Pressure

- Pump system faulted on high outlet pressure
- Check regulator settings
- Press F3 to reset

10. SYSTEM MAINTENANCE

10.1 CRANKCASE OIL

The IBEX pump unit is equipped with an hour meter and an automatic reminder to change pump oil; Red light, slow flash (does not affect operation). See page 10 for instructions to reset the light indicator.

Initially the Crankcase Oil must be changed after the first 50 operating hours.

After that it should be changed after every 500 hours of operation.

Examples of 500 hours operation:

15 weeks of 5-hour operation per day

9 weeks of 8-hour operation per day

6 weeks of 12-hour operation per day

3 weeks of 24-hour operation per day

The chart to the right indicates oil capacity for each pump.

Crankcase Oil Capacity	
Giant P200 series	9 fl oz.
Giant P56W	14 fl oz.
Giant P59W	14 fl oz.
Giant P420A	30 fl oz.

ISO-68 HYDRAULIC MINERAL OIL IS RECCOMENDED FOR ALL APPLICATIONS

In the event that ISO-68 is not available, SAE-20 CRANKCASE MINERAL OIL may be substituted

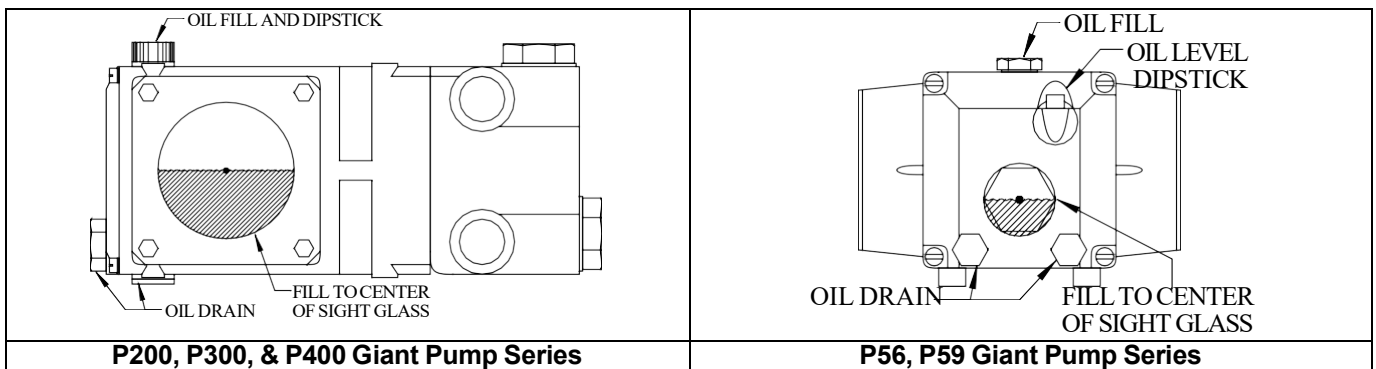

Figure 20 – Crankcase Oil Levels

10.2 ELECTRICAL MOTOR SERVICE

Two types of electrical motors are used on the MicroCool® pump modules. Some small motors have sealed rotor bearings, and some require lubrication periodically. Refer to the motor nameplate for the type of motor. If the motor is equipped with external grease nipples refer to the chart below for lubrication instructions.

Service Condition	Time Intervals
Standard	Every 3 Years
Severe	Every 1 Year
Seasonal	Lubricate at beginning of season

Electrical motors on the pump modules are pre-greased with a polyurea mineral oil NGLI grade 2-type grease unless stated otherwise on the motor nameplate. Some compatible brands of polyurea mineral base type grease are: Chevron SRI #2, Rykon Premium #2, Shell Oil Doilum R or Texaco Polystar RB. Motors are properly lubricated at the time of manufacture and do not need to be lubricated at the time of installation.

NOTE: Over greasing bearings can cause premature bearing and/or motor failure. The amount of grease added to the motor should be carefully controlled. One crank of the grease gun handle is usually sufficient.

10.3 INLET WATER FILTERS

The inlet water filter cartridges, 5-micron, and 10-micron must be inspected once per week or as needed. The change interval of the filter cartridges depends entirely upon the cleanliness of the inlet water. When the “outlet gauge” shows a significant drop in pressure during operation it is time to change the filters. The filter cartridges should be changed at least once every year.

Figure 21 – Inlet Water Filtration Assembly

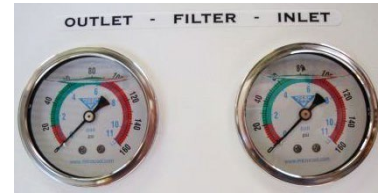
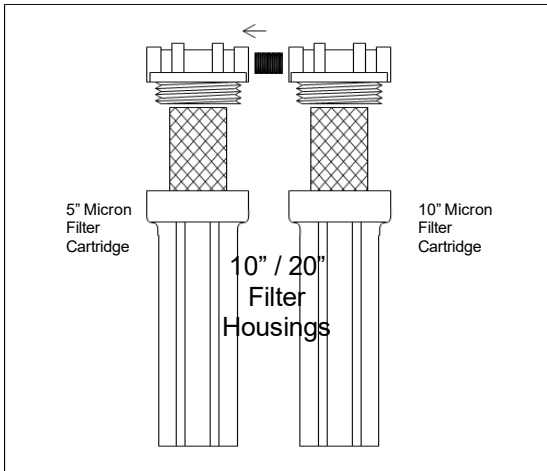

Re-ordering Information

10\" - 5 Micron Filter Cartridge
Part # PFC1005

10\" - 10 Micron Filter Cartridge
Part # PFC1010

20\" - 5 Micron Filter Cartridge
Part # PFC2005

20\" - 10 Micron Filter Cartridge
Part # PFC2010

10.4 ATOMIZATION LINES/MANIFOLD HOSES

The hoses and lines should be periodically inspected for damage such as cuts and abrasions. Also check that the hoses have not come into contact with sharp edges or are vibrating against an abrasive surface.

10.5 SYSTEM FLUSH – SHUT DOWN - WINTERIZING

If the system is to be SHUT DOWN for a period of time, all automatic drain valves or end plugs should be removed and the complete system flushed. Then all water remaining in the lines should be purged with compressed air. The supply water to the pump module should be turned off. Empty filter housings of any remaining water and replace filter cartridges with new dry cartridges. Turn off electrical power to pump module. This will help to prevent water freezing and damaging the pump or its components.

Note: The pump unit has an automatic flush feature that will flush the pump every 96 hours (4 days) of non-operation. This flush does not start the pump motor; it only opens the inlet solenoid valve and the drain solenoid valve for 30 seconds. This keeps the water in the pump system fresh and limits the chance of the water becoming stagnant. This flush will occur if the pump unit is powered and is connected to a water supply. To disable, shut off the power and/or the water supply to the pump unit.

10.6 INLET WATER PRESSURE SWITCH

The pressure switch is a hydraulically actuated, stainless steel enclosed switch. Platinum coated contacts complete a 24vac control circuit. The body of the pressure switch has a 150 P.S.I. (10.3 BAR) maximum pressure rating. Cut off sensitivity is adjustable from 12 to 100 P.S.I. (0.3 - 6.9 BAR). Switches are preset to 10 PSI (0.7BAR) at the factory.

10.7 OPTIONAL EXTRAS

ULTRAVIOLET FILTER (UV): High Intensity Light to kill bacteria and germs.

CAUTION: DO NOT LOOK DIRECTLY AT THE UV LIGHT AS EYE DAMAGE MAY OCCUR

The UV light filter is shipped with the UV bulb in a separate protective tube. The bulb is installed prior to starting the pump unit.

Instructions to install (or remove) light bulb:

1. Do not touch the bulb with bare hands.
2. Remove the lamp receptacle (top) by pressing the release clips on filter housing. **(Figure 1.)**
3. Carefully insert the UV lamp into the filter housing. **(Figure 2.)**
4. While holding the lamp at the green ceramic top, determine the correct orientation of the pins and gently plug the lamp into the receptacle, ensuring it goes in all the way. **(Figure 3.)**
5. Finish by aligning the lamp receptacle with filter housing and ensure that it clicks into place.
6. The UV ballast is installed on the left under side of the pump housing. When the pump unit is running, there is a red number indicated on the display. This number represents the decreasing life span of the light bulb in days.
7. Once the number has reached 0 the ballast will emit an audible alarm, indicating that the UV bulb needs to be replaced.
8. Once the bulb is replaced, press the reset button on the side of the ballast while the pump is running, and the day countdown will resume at 365.
9. Proper disposal of all old bulbs is advised. Please contact your local municipality for disposal instruction. Do not discard bulbs with regular waste.



Figure 1. Push clips on filter housing to release the bulb receptacle (top).



Figure 2. Lamp placed into filter housing.



Figure 3. Lamp plugs into receptacle. 2-Piece Filter Housing clicks into place.



Figure 4. Press reset button on side of ballast while pump is running.

See UV Manual for more details and specifications.

11. **TROUBLE SHOOTING**

11.1 PUMP MODULE HAS STOPPED RUNNING

Pump system has faulted out due to loss in supply water pressure or VFD fault. Pump will try re-start in 30 seconds. If the water pressure has not been restored, or the VFD fault automatically re-set, the pump system will remain off for another 30 seconds. After the second 30 second interval the pump system will again try to re-start. If the water pressure has been restored or VFD was able to automatically re-set, the fault will clear and the system will return to normal operation. If the fault(s) has not been cleared, the pump system will lock-out and the LCD Display will indicate the Fault.

11.2 INLET WATER PRESSURE FAULT:

Water supply to pump module may be inadequate. Check the following:

- Inlet water pressure has dropped below 20 P.S.I. (1.4 BAR) (correct water pressure)
- Dirty filter elements (inspect and replace if necessary)
- Water supply turned off (make sure it is on)
- Restriction in water line to pump (look for partially closed valve or another device)
- Other lines drawing water off-line feeding pump module (the line should feed only the module).

11.3 VARIABLE FREQUENCY DRIVE (VFD) FAULT CODES

DRIVE DISPLAY	DESCRIPTION	POSSIBLE CAUSES
F0021	Undervoltage fault on the intermediate circuit.	<ul style="list-style-type: none"> • Wrong voltage supply: check if the data on the inverter label complies with the power supply and parameter P0296. • Supply voltage too low, producing voltage on the DC link below the minimum value (in P0004): Ud<200 Vdc in 200-240 Vac (P0296=0). Ud<360 Vdc in 380-480 Vac (P0296=1). Ud<500 Vdc in 500-600 Vac (P0296=2). • Phase fault in the input. • Fault in the pre-charge circuit.
F0022	Overvoltage fault on the intermediate circuit.	<ul style="list-style-type: none"> • Wrong voltage supply: check if the data on the inverter label complies with the power supply and parameter P0296. • Supply voltage is too high, producing voltage on the DC link above the maximum value (in P0004): Ud>410 Vdc in 200-240 Vac (P0296=0). Ud>810 Vdc in 380-480 Vac (P0296=1). Ud>1000 Vdc in 500-600 Vac (P0296=2). • Load inertia is too high or deceleration ramp is too fast. • P0151 or P0153 setting is too high.
F0031		<ul style="list-style-type: none"> • Communication card failure
F0048	Overload fault on the power pack with IGBTs (3 s in 1.5XL).	<ul style="list-style-type: none"> • Inverter output overcurrent (>2xl)
A0050/F0051	Drive over-temperature	<ul style="list-style-type: none"> • Possible Cooling Fan Failure
A0046/F0072	Motor load to high	<ul style="list-style-type: none"> • Possible Pump failure
F0070	Overcurrent or short-circuit on the output, DC link or braking resistor.	<ul style="list-style-type: none"> • Short-circuit between two motor phases. • Short-circuit of the rheostatic braking resistor connecting cables. • IGBTs module in short-circuit or damaged • Start with too short acceleration ramp. • Start with motor spinning without the Flying Start function.

F0072	Motor overload fault (60 s in 1.5xInom)	<ul style="list-style-type: none"> • P0156, P0157, P0158 setting is too low in relation to the motor operating current. • Overload on the motor shaft
F0074	<p>Ground overcurrent fault.</p> <p>Note: This failure may be disabled by setting P0343 = 0</p>	<ul style="list-style-type: none"> • Short-circuit to the ground in one or more output phases. • Motor cable capacitance too high, causing current peaks in the output.
F0076	This fault indicates the motor presents phase loss, imbalanced phase current or is disconnected.	<ul style="list-style-type: none"> • Motor wiring or connection error. • Loss of moto connection with the drive or broken wire.
F0078	Overtemperature fault measured on the motor temperature sensor (Triple PTC) via analog input Alx or digital input DIx	<ul style="list-style-type: none"> • Overload on the motor shaft. • Load cycle is too high (high number of starts and stops per minute). • High ambient temperature around the motor. • Poor contact or short-circuit (3k9<RPTC<0K1). • Motor thermistor not installed. • Motor shaft in stuck.

For more detailed descriptions reference WEG manual.

12. WARRANTY

Products manufactured by MicroCool® bear the following limited warranty:

MicroCool warrants that the goods to be delivered will be of the kind and quality described in the sales order or contract and will be free of defects in workmanship or material. Should any failure to conform to this warranty appear within the time limit stated below, after the initial date of delivery, MicroCool shall, upon notification thereof, and written substantiation that the goods have been stored, installed, maintained, and operated in accordance with the seller's recommendations and standard industry practice, correct such defect by suitable repair or replacement at its own expense. This warranty is limited to repairing or replacing products that the manufacturer's investigation shows were defective at the time of shipment by the manufacturer. An RMA number must be obtained from MicroCool® before returning a product for warranty consideration or repair.

Warranty period: **One (1) year on all MicroCool manufactured goods**
Two (2) years on coupled Weg motor and VF Drive
The lesser of One (1) year or 4,000 hours use on pump head

Notification Period: Notify MicroCool within 15 days of determining defect.
Product Return Period: Return defect product within 30 days to MicroCool
All products subject to this warranty shall be returned for examination, repair or replacement, freight pre-paid to:

MicroCool®
72216 Northshore Street #103-104
Thousand Palms, California 92276, USA

Phone# +1-760-322-1111
FAX# +1-760-343-1820

fog@microcool.com

www.microcool.com

This warranty is exclusive and is in lieu of any warranty or merchantability, fitness for a particular purpose or other warranty of quality, whether express or implied, except of title and against patent infringement. Correction of non-conformities, in the manner and for the period of time provided above, shall constitute fulfillment of all liabilities of the seller to the purchaser with respect to, or arising out of the goods, whether based on contract negligence, strict tort or otherwise.

LIMITATION OF LIABILITY - Repair or replacement of defective products as provided above is the sole and exclusive remedy provided hereunder and the seller shall not under any circumstances be liable for special or consequential damages such as, but not limited to, damage or loss of other property or equipment, loss of profits, or revenue, cost of capital, cost of purchased or replacement goods, or claims or customers of purchaser for service interruptions. The remedies of the purchaser set forth are exclusive and the liability of seller with respect to any contract, or anything done in connection therewith such as the performance or breach thereof, or from the manufacture, sale, delivery, resale, installation or use of any goods covered by or furnished under this contract whether arising out of contract, negligence, strict tort, or under any warranty, or otherwise, shall not, except as expressly provided herein, exceed the price of the goods upon which such liabilities based. This is the only warranty on any MicroCool® product; no other writing or description in the literature shall be construed as a warranty. Products manufactured by other than MicroCool® bear the following limited warranty:

Seller warrants that the goods manufactured by others will conform to the description herein stated. No other warranty expressed or implied is made, and the warranty of the manufacturer is hereby assigned and transferred to the buyer. Furthermore, except for the manufacturer's warranty, if any, the products sold hereunder are sold as is. MicroCool® is not liable for any incidental or consequential damages in connection with these products.

In addition to all the above, MicroCool® accepts no liability if the system is used to dispense corrosive, toxic or other non-approved agents. MicroCool® will not be responsible for poor water quality damage or nozzle blockage due to poor water quality.

MicroCool®



CERTIFICATE OF COMPLIANCE

Certificate Number 20190307-E352513
Report Reference E352513-20120418
Issue Date 2019-MARCH-07

Issued to: MICROCOOL
72216 Northshore St. Unit 103-104
THOUSAND PALMS CA 92276

This is to certify that representative samples of o INDUSTRIAL CONTROL PANELS
USL, CNL - Industrial control panels.

Have been investigated by UL in accordance with the Standard(s) indicated on this Certificate.

Standard(s) for Safety: UL 508A - Industrial Control Panels and C22.2 No. 14-10 - Industrial Control Equipment.

Additional Information: See the UL Online Certifications Directory at www.ul.com/database for additional information

Only those products bearing the UL Certification Mark should be considered as being covered by UL's Certification and Follow-Up Service.

Look for the UL Certification Mark on the product.



Bruce Mahrenholz, Assistant Chief Engineer, Global Inspection and Field Services
UL LLC

Any information and documentation involving UL Mark services are provided on behalf of UL LLC (UL) or any authorized licensee of UL. For questions, please contact a local UL Customer Service Representative at <http://ul.com/aboutul/locations/>



14.2 IBEX 4-11 GALLON REAR VIEW

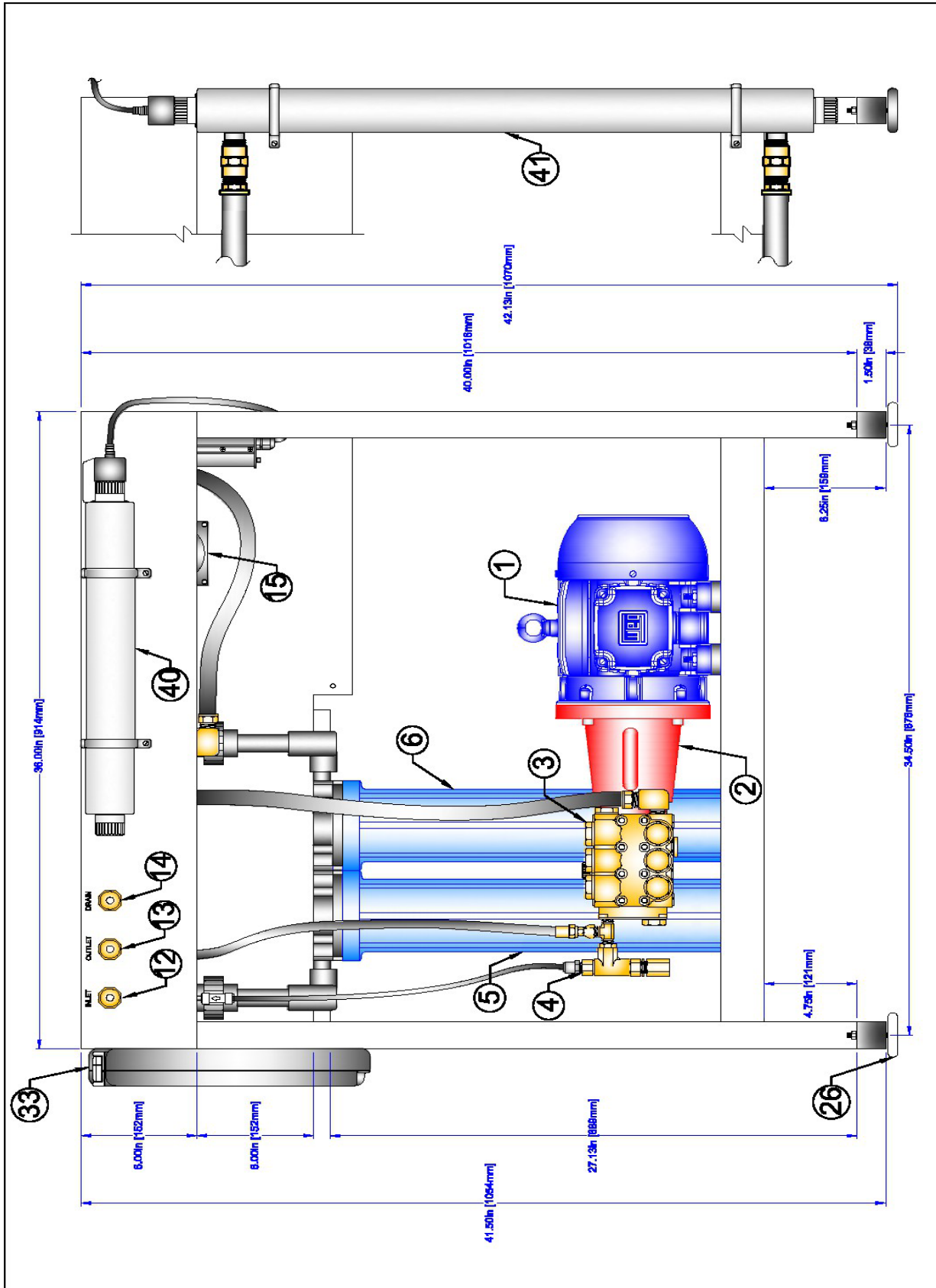

<p>MicroCool Thousand Palms CA USA +1-705-322-1111 info@microcool.com www.microcool.com</p>		<p>ibex LARGE FRAME REAR VIEW IBEX-4 THRU 11</p>	
<p>UNAUTHORIZED CHANGES & USES: The drafter/generator of these plans will not be responsible for any unauthorized changes or use of these plans. All changes to the plans must be in writing and must be approved by the center of trade plans.</p>		<p>2 OF 11 SHEETS</p>	
<p>DATE: 10/27/11 BY: JAP JOB NO: 118207</p>		<p>DRAWN: DA DESIGNED: JA CHECKED: AD</p>	
<p>DESCRIPTION: NEW P.C.A. TERMINAL BLOCKS ADDED</p>		<p>SCALE: NA JOB NUMBER: NA DATE: 11/20/11</p>	
<p>REVISIONS</p>		<p>FILE NO.</p>	
<p>TOLERANCES UNLESS OTHERWISE SPECIFIED: DIMENSIONS ARE IN INCHES FRACTIONS: 1/16, 1/8, 1/4, 3/8, 1/2, 5/8, 3/4, 7/8 DECIMALS: .0005, .001, .002, .005, .010, .015, .020, .030, .040, .050, .060, .070, .080, .090, .100 THREE PLACE DECIMAL FILL: .001 FINISH: ENAMEL WHITE POWDER COAT</p>		<p>35 YEARS MICRO COOL TM</p>	

14.3 IBEX 4-11 GALLON RIGHT SIDE VIEW

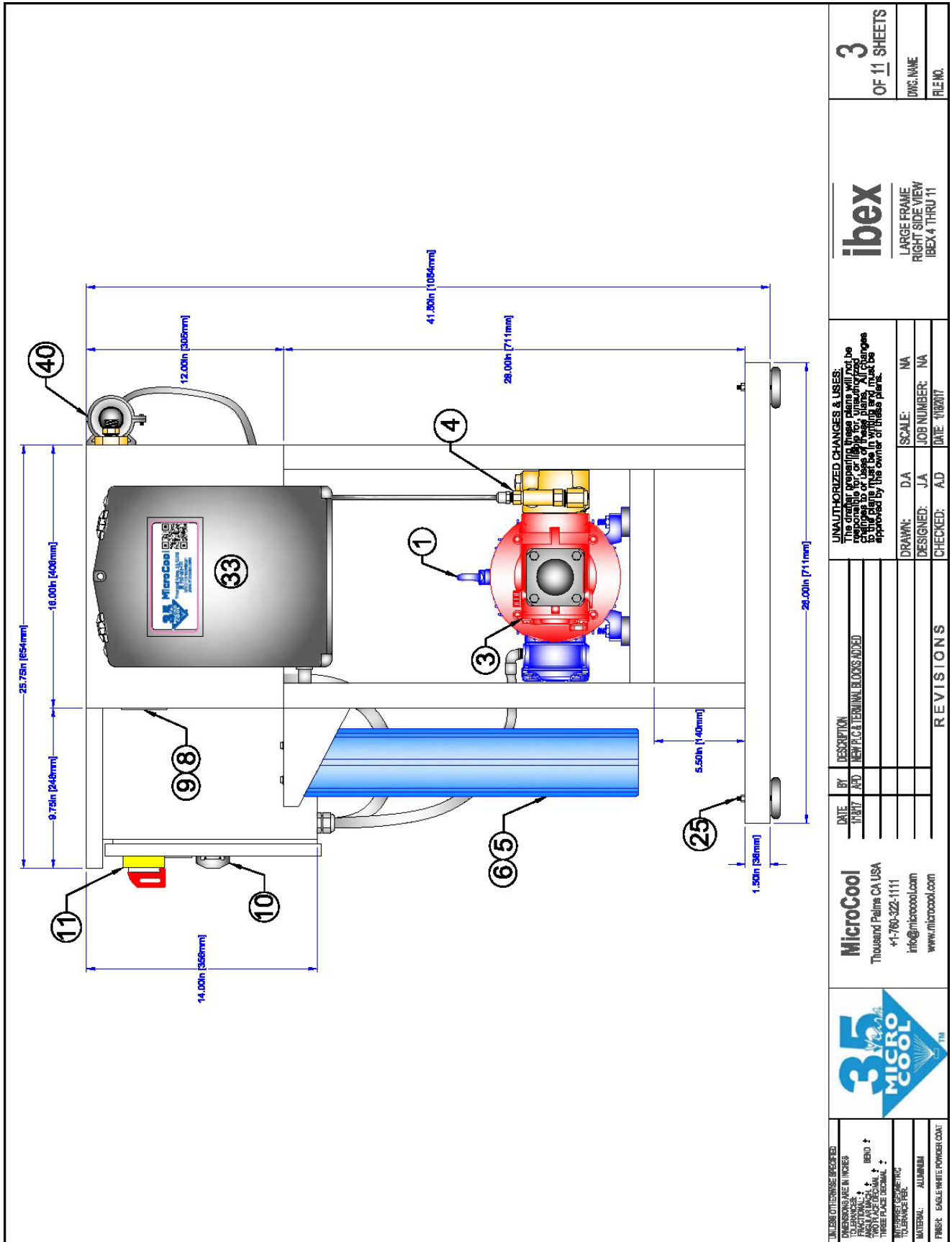

3
OF 11 SHEETS

DWG. NAME
FILE NO.

ibex
LARGE FRAME
RIGHT SIDE VIEW
IBEX 4 THRU 11

UNAUTHORIZED CHANGES & USES:
The drafter, engineer, or designer of these plans will not be held responsible for any errors or omissions in these plans. All changes to these plans must be in writing and must be approved by the center of design plans.

DRAWN:	D.A	SCALE:	NA
DESIGNED:	J.A	JOB NUMBER:	NA
CHECKED:	A.D	DATE:	10/20/17

DATE	BY	DESCRIPTION
11/17/17	A.D	NEW P/L & TERMINAL BLOCKS ADDED

MicroCool
Thousand Palms CA USA
+1-761-322-1111
info@microcool.com
www.microcool.com



UNLESS OTHERWISE SPECIFIED:
DIMENSIONS ARE IN INCHES
FRACTIONAL DIMENSIONS TO NEAREST 1/16"
THREE PLACE DECIMAL DIMENSIONS TO NEAREST 0.001"
TOLERANCE PER:
MATERIAL: ALUMINUM
FINISH: ENAMEL WHITE POWDER COAT

REVISIONS

14.7 IBEX 4-11 GALLON BOTTOM VIEW

16.00 in [406mm]

9.75 in [248mm]

27

36

37

38

39

ibex

LARGE FRAME
BOTTOM VIEW
IBEX 4 THRU 11

7
OF 11 SHEETS

DWG. NAME
FILE NO.

UNAUTHORIZED CHANGES & USES:
The drawings on these plans will not be changed or altered in any way without the approval of the designer. All changes to these plans must be approved by the owner of these plans.

DRAWN: D.A. SCALE: NA
DESIGNED: J.A. JOB NUMBER: NA
CHECKED: A.D. DATE: 1/26/07

DATE	BY	DESCRIPTION
1/26/07	A.P.D.	NEW P.C. & TERMINAL BLOCKS ADDED

REVISIONS

MicroCool
Thousand Palms CA USA
+1-700-322-1111
info@microcool.com
www.microcool.com



35
MICRO
COOL
TM

UNLESS OTHERWISE SPECIFIED:
DIMENSIONS ARE IN INCHES
FRACTIONS: 1/16" & 1/32"
TOLERANCES: ±.005"
THREE PLACE DECIMAL, ±

FINISH: BRIGHT ANODIZED ALUMINUM
PINK: ENIGLE WHITE POWDER COAT

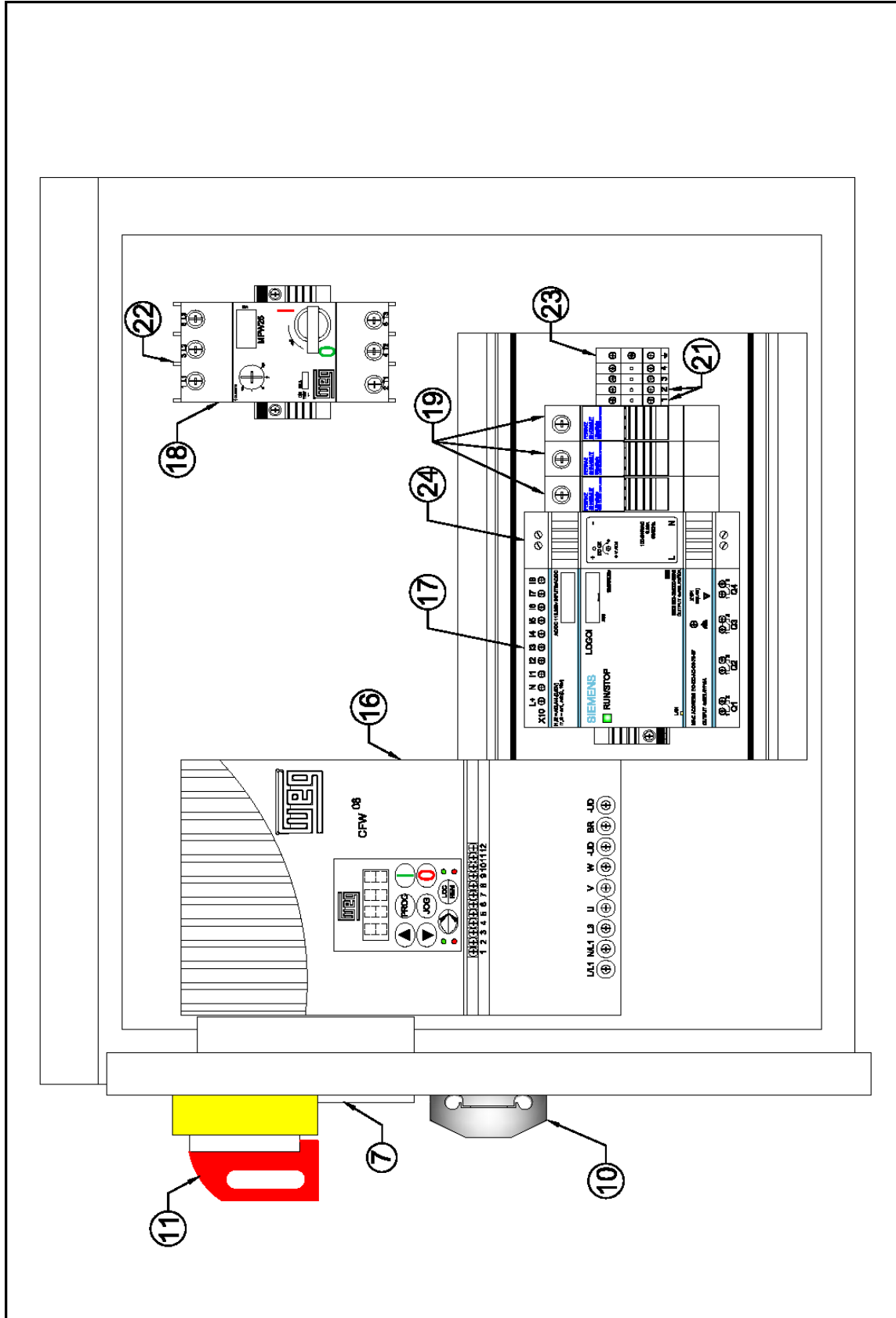
14.9 IBEX 4-11 GALLON 380-575V CONTROL PANEL



			
<p>UNLESS OTHERWISE SPECIFIED: DIMENSIONS ARE IN INCHES TOLERANCES: ± .005 AND ALL DIMENSIONS ± .005 THREE PLACE DECIMAL ± .005 THREE PLACE DECIMAL ± .005</p>		<p>UNAUTHORIZED CHANGES & USES: ANY CHANGES TO THIS DRAWING OR THE USE OF THIS DRAWING FOR ANY OTHER PROJECT WITHOUT THE WRITTEN PERMISSION OF MICROCOOL SHALL BE AT THE USER'S RISK. ALL CHANGES TO THIS DRAWING MUST BE APPROVED BY THE OWNER OR HIS/HER AGENT.</p>	
<p>MicroCool Thousand Palms CA USA +1-760-322-1111 info@microcool.com www.microcool.com</p>		<p>LARGE FRAME DRIVE 380-575V IBEX 4 THRU 11</p>	
<p>DATE: 1/20/17 BY: APD DESCRIPTION: NEW I.C.A. TERMINAL BLOCKS ADDED</p>		<p>9 OF 11 SHEETS DWG. NAME: IBEIN</p>	
<p>DATE: 1/10/17 BY: AD CHECKED: AD DATE: 1/10/17</p>		<p>DRAWN: D.A. SCALE: NA DESIGNED: J.A. JOB NUMBER: NA</p>	
<p>REVISIONS</p>		<p>FILE NO.</p>	

NOTES

UPGRADE OPTIONS

- ③⑥ VECTOR SENSOR (VCT2003)
- ③⑦ ELECTRICAL QUICK DISCONNECT
6 PORT - SENSOR
- ③⑧ COMMUNICATION CABLE - 100 FEET
STANDARD (EWG2204)
- ③⑨ PANEL ELECTRICAL QUICK
DISCONNECT - OUTPUT
- ④⑩ UV LIGHT 1-5 GPM (UVF0001)
- ④⑪ UV LIGHT 6-11 GPM (UVF0002)

UNLESS OTHERWISE SPECIFIED:
DIMENSIONS ARE IN INCHES
TOLERANCES:
FRACTIONS DECIMALS BENDS
1/16" 0.0625" 0.001" 0.001"
1/8" 0.125" 0.001" 0.001"
1/4" 0.250" 0.001" 0.001"
1/2" 0.500" 0.001" 0.001"
3/4" 0.750" 0.001" 0.001"
1" 1.000" 0.001" 0.001"
MATERIAL: ALUMINUM
FINISH: ENAMEL WHITE POWDER COAT



MicroCool
Thousand Palms CA USA
+1-760-322-1111
Info@microcool.com
www.microcool.com

DATE	BY	DESCRIPTION
TWO	ADD	NEW V.C. & TERMINAL BLOCKS ADDED

UNAUTHORIZED CHANGES & USES:
The drafter preparing these plans will not be responsible for, or liable for, unauthorized changes or alterations to the original drawings approved by the owner of these plans.

DRAWN: D.A	SCALE: NA
DESIGNED: J.A	JOB NUMBER: NA
CHECKED: A.D	DATE: 11/27/17

ibex
LARGE FRAME
NOTES
IBEX4 THRU 11

11
OF 11 SHEETS
DWG. NAME
FILE NO.

14.12 IBEX 4-11 GALLON 208-240V ELECTRICAL DIAGRAM